

**SIEMENS**

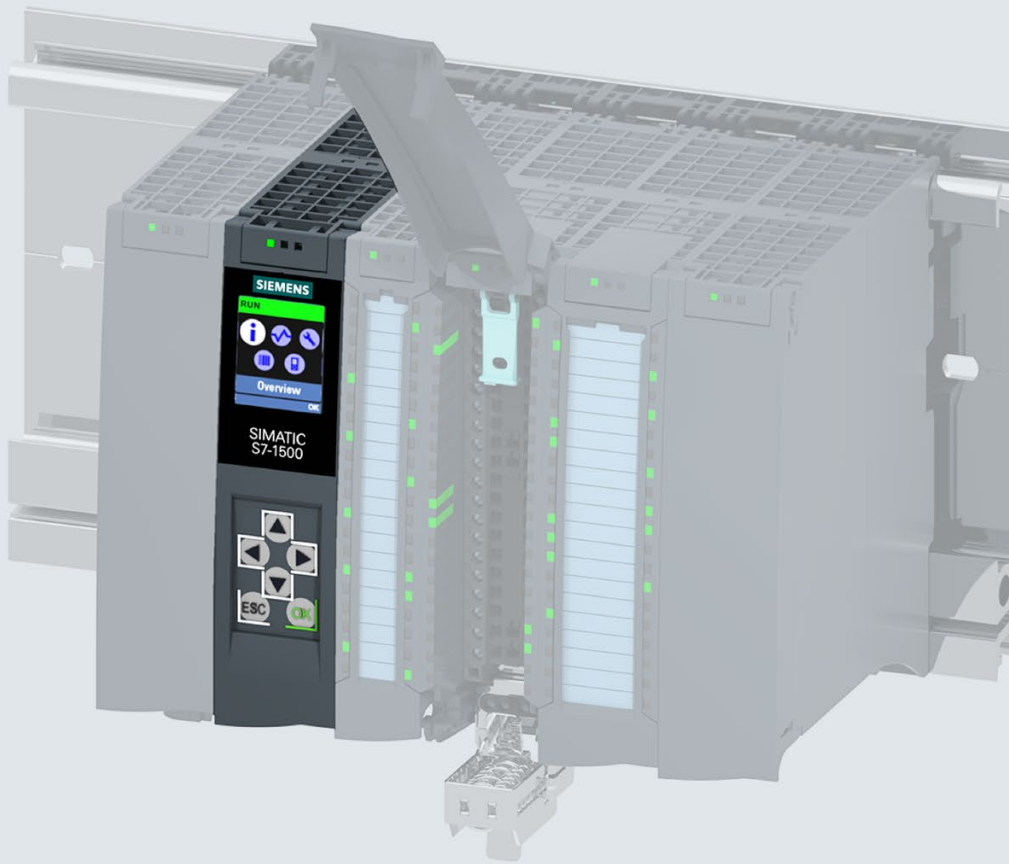

Manual

# SIMATIC

**S7-1500**

CPU 1511-1 PN (6ES7511-1AK02-0AB0)

Edition

12/2017

[support.industry.siemens.com](http://support.industry.siemens.com)

# SIEMENS

## SIMATIC

S7-1500  
CPU 1511-1 PN  
(6ES7511-1AK02-0AB0)

Manual

Preface

---

Documentation guide

---

1

Product overview

---

2

Connecting up

---

3

Interrupts, error messages,  
diagnostics and system  
alarms

---

4

Technical specifications

---

5

Dimensional drawing



---

A

## Legal information

### Warning notice system

This manual contains notices you have to observe in order to ensure your personal safety, as well as to prevent damage to property. The notices referring to your personal safety are highlighted in the manual by a safety alert symbol, notices referring only to property damage have no safety alert symbol. These notices shown below are graded according to the degree of danger.

 <b>DANGER</b>
indicates that death or severe personal injury <b>will</b> result if proper precautions are not taken.
 <b>WARNING</b>
indicates that death or severe personal injury <b>may</b> result if proper precautions are not taken.
 <b>CAUTION</b>
indicates that minor personal injury can result if proper precautions are not taken.
<b>NOTICE</b>
indicates that property damage can result if proper precautions are not taken.

If more than one degree of danger is present, the warning notice representing the highest degree of danger will be used. A notice warning of injury to persons with a safety alert symbol may also include a warning relating to property damage.

### Qualified Personnel

The product/system described in this documentation may be operated only by **personnel qualified** for the specific task in accordance with the relevant documentation, in particular its warning notices and safety instructions. Qualified personnel are those who, based on their training and experience, are capable of identifying risks and avoiding potential hazards when working with these products/systems.

### Proper use of Siemens products

Note the following:

 <b>WARNING</b>
Siemens products may only be used for the applications described in the catalog and in the relevant technical documentation. If products and components from other manufacturers are used, these must be recommended or approved by Siemens. Proper transport, storage, installation, assembly, commissioning, operation and maintenance are required to ensure that the products operate safely and without any problems. The permissible ambient conditions must be complied with. The information in the relevant documentation must be observed.

### Trademarks

All names identified by ® are registered trademarks of Siemens AG. The remaining trademarks in this publication may be trademarks whose use by third parties for their own purposes could violate the rights of the owner.

### Disclaimer of Liability

We have reviewed the contents of this publication to ensure consistency with the hardware and software described. Since variance cannot be precluded entirely, we cannot guarantee full consistency. However, the information in this publication is reviewed regularly and any necessary corrections are included in subsequent editions.

# Preface

## Purpose of the documentation

This manual supplements the system manual of the S7-1500 automation system/ET 200MP distributed I/O system as well as the function manuals. This manual contains a description of the module-specific information. The system-related functions are described in the system manual. All system-spanning functions are described in the function manuals.

The information provided in this manual and the system manual enables you to commission the CPU 1511-1 PN.

## Conventions

STEP 7: In this documentation, "STEP 7" is used as a synonym for all versions of the configuration and programming software "STEP 7 (TIA Portal)".

Please also observe notes marked as follows:

---

### Note

A note contains important information on the product described in the documentation, on the handling of the product or on the section of the documentation to which particular attention should be paid.

---

## Security information

Siemens provides products and solutions with industrial security functions that support the secure operation of plants, systems, machines and networks.

In order to protect plants, systems, machines and networks against cyber threats, it is necessary to implement – and continuously maintain – a holistic, state-of-the-art industrial security concept. Siemens' products and solutions constitute one element of such a concept.

Customers are responsible for preventing unauthorized access to their plants, systems, machines and networks. Such systems, machines and components should only be connected to an enterprise network or the internet if and to the extent such a connection is necessary and only when appropriate security measures (e.g. firewalls and/or network segmentation) are in place.

For additional information on industrial security measures that may be implemented, please visit (<http://www.siemens.com/industrialsecurity>).

Siemens' products and solutions undergo continuous development to make them more secure. Siemens strongly recommends that product updates are applied as soon as they are available and that the latest product versions are used. Use of product versions that are no longer supported, and failure to apply the latest updates may increase customers' exposure to cyber threats.

To stay informed about product updates, subscribe to the Siemens Industrial Security RSS Feed under (<http://www.siemens.com/industrialsecurity>).

## Siemens Industry Online Support

You can find current information on the following topics quickly and easily here:

- **Product support**

All the information and extensive know-how on your product, technical specifications, FAQs, certificates, downloads, and manuals.

- **Application examples**

Tools and examples to solve your automation tasks – as well as function blocks, performance information and videos.

- **Services**

Information about Industry Services, Field Services, Technical Support, spare parts and training offers.

- **Forums**

For answers and solutions concerning automation technology.

- **mySupport**

Your personal working area in Industry Online Support for messages, support queries, and configurable documents.

This information is provided by the Siemens Industry Online Support in the Internet (<https://support.industry.siemens.com>).

## Industry Mall

The Industry Mall is the catalog and order system of Siemens AG for automation and drive solutions on the basis of Totally Integrated Automation (TIA) and Totally Integrated Power (TIP).

Catalogs for all the products in automation and drives are available on the Internet (<https://mall.industry.siemens.com>).

# Table of contents

	<b>Preface</b> .....	<b>4</b>
<b>1</b>	<b>Documentation guide</b> .....	<b>7</b>
<b>2</b>	<b>Product overview</b> .....	<b>11</b>
2.1	Applications of the S7-1500 CPU .....	11
2.2	Hardware properties .....	18
2.3	Firmware functions.....	20
2.4	Operating and display elements .....	24
2.4.1	Front view of the CPU with closed front panel.....	24
2.4.2	Front view of the CPU without front panel and view from below .....	26
2.4.3	Rear view of the CPU .....	27
2.5	Operating mode buttons .....	28
<b>3</b>	<b>Connecting up</b> .....	<b>29</b>
<b>4</b>	<b>Interrupts, error messages, diagnostics and system alarms</b> .....	<b>33</b>
4.1	Status and error display of the CPU .....	33
<b>5</b>	<b>Technical specifications</b> .....	<b>36</b>
<b>A</b>	<b>Dimensional drawing</b> .....	<b>48</b>

## Documentation guide

The documentation for the SIMATIC S7-1500 automation system and the SIMATIC ET 200MP distributed I/O system is arranged into three areas. This arrangement enables you to access the specific content you require.

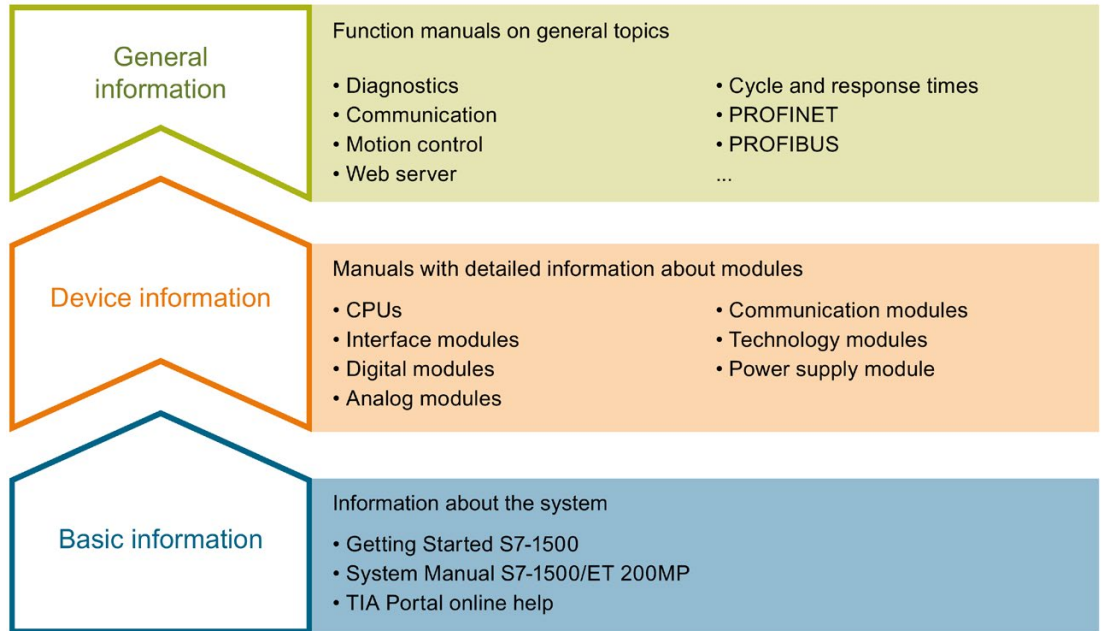

### Basic information

The System Manual and Getting Started describe in detail the configuration, installation, wiring and commissioning of the SIMATIC S7-1500 and ET 200MP systems. The STEP 7 online help supports you in the configuration and programming.

### Device information

Product manuals contain a compact description of the module-specific information, such as properties, wiring diagrams, characteristics and technical specifications.

### General information

The function manuals contain detailed descriptions on general topics regarding the SIMATIC S7-1500 and ET 200MP systems, e.g. diagnostics, communication, motion control, Web server, OPC UA.

You can download the documentation free of charge from the Internet (<http://w3.siemens.com/mcms/industrial-automation-systems-simatic/en/manual-overview/Pages/Default.aspx>).

Changes and supplements to the manuals are documented in a Product Information.

You can download the product information free of charge from the Internet (<https://support.industry.siemens.com/cs/us/en/view/68052815>).

### Manual Collection S7-1500/ET 200MP

The Manual Collection contains the complete documentation on the SIMATIC S7-1500 automation system and the ET 200MP distributed I/O system gathered together in one file.

You can find the Manual Collection on the Internet (<https://support.industry.siemens.com/cs/ww/en/view/86140384>).

### SIMATIC S7-1500 comparison list for programming languages

The comparison list contains an overview of which instructions and functions you can use for which controller families.

You can find the comparison list on the Internet (<https://support.industry.siemens.com/cs/ww/en/view/86630375>).

### "mySupport"

With "mySupport", your personal workspace, you make the best out of your Industry Online Support.

In "mySupport", you can save filters, favorites and tags, request CAx data and compile your personal library in the Documentation area. In addition, your data is already filled out in support requests and you can get an overview of your current requests at any time.

You must register once to use the full functionality of "mySupport".

You can find "mySupport" on the Internet (<https://support.industry.siemens.com/My/ww/en>).

### "mySupport" - Documentation

In the Documentation area in "mySupport" you can combine entire manuals or only parts of these to your own manual.

You can export the manual as PDF file or in a format that can be edited later.

You can find "mySupport" - Documentation on the Internet (<http://support.industry.siemens.com/My/ww/en/documentation>).



## "mySupport" - CAx data

In the CAx data area in "mySupport", you can access the current product data for your CAx or CAe system.

You configure your own download package with a few clicks.

In doing so you can select:

- Product images, 2D dimension drawings, 3D models, internal circuit diagrams, EPLAN macro files
- Manuals, characteristics, operating manuals, certificates
- Product master data

You can find "mySupport" - CAx data on the Internet (<http://support.industry.siemens.com/my/ww/en/CAxOnline>).

## Application examples

The application examples support you with various tools and examples for solving your automation tasks. Solutions are shown in interplay with multiple components in the system - separated from the focus on individual products.

You will find the application examples on the Internet (<https://support.industry.siemens.com/sc/ww/en/sc/2054>).

## TIA Selection Tool

With the TIA Selection Tool, you can select, configure and order devices for Totally Integrated Automation (TIA).

This tool is the successor of the SIMATIC Selection Tool and combines the known configurators for automation technology into one tool.

With the TIA Selection Tool, you can generate a complete order list from your product selection or product configuration.

You can find the TIA Selection Tool on the Internet (<http://w3.siemens.com/mcms/topics/en/simatic/tia-selection-tool>).

## SIMATIC Automation Tool

You can use the SIMATIC Automation Tool to perform commissioning and maintenance activities simultaneously on various SIMATIC S7 stations as a bulk operation independent of the TIA Portal.

General function overview:

- Network browsing and creation of a table showing the accessible devices in the network.
- Flashing of device LEDs or HMI display to locate a device
- Downloading of addresses (IP, subnet, gateway) to a device
- Downloading the PROFINET name (station name) to a device
- Placing a CPU in RUN or STOP mode
- Setting the time in a CPU to the current time of your PG/PC
- Downloading a new program to a CPU or an HMI device
- Downloading from CPU, downloading to CPU or deleting recipe data from a CPU
- Downloading from CPU or deleting data log data from a CPU
- Backup/restore of data from/to a backup file for CPUs and HMI devices
- Downloading service data from a CPU
- Reading the diagnostics buffer of a CPU
- Performing a CPU memory reset
- Resetting devices to factory settings
- Downloading a firmware update to a device

You can find the SIMATIC Automation Tool on the Internet (<https://support.industry.siemens.com/cs/ww/en/view/98161300>).

## PRONETA

With SIEMENS PRONETA (PROFINET network analysis), you analyze the PROFINET network during commissioning. PRONETA features two core functions:

- The topology overview independently scans PROFINET network and all connected components.
- The IO check is a fast test of the wiring and the module configuration of a system.

You can find SIEMENS PRONETA on the Internet (<https://support.industry.siemens.com/cs/ww/en/view/67460624>).

# Product overview

## 2.1 Applications of the S7-1500 CPU

### Area of application

SIMATIC S7-1500 is the modular control system for a wide variety of automation applications in discrete automation.

The modular and fanless design, simple implementation of distributed structures, and user-friendly operation make SIMATIC S7-1500 the economic and convenient solution for a variety of tasks.

Areas of application of the SIMATIC S7-1500 are, for example:

- Special-purpose machines
- Textile machinery
- Packaging machines
- General mechanical engineering
- Controller engineering
- Machine tool engineering
- Installation engineering
- Electrical industry and crafts
- Automobile engineering
- Water/waste water
- Food & Beverage

Areas of application of the SIMATIC S7-1500T are, for example:

- Packaging machines
- Converting application
- Assembly automation

Several CPUs with various levels of performance and a comprehensive range of modules with many convenient features are available. Fail-safe CPUs enable use in fail-safe applications. The modular design allows you to use only the modules that you need for your application. The controller can be retrofitted with additional modules at any time to expand its range of tasks.

High industrial capability from the high resistance to EMC, shock and vibration enable universal use of the SIMATIC S7-1500.

**Performance segments of the standard, compact, fail-safe and technology CPUs**

The CPUs can be used for smaller and mid-range applications, as well as for the high-end range of machine and plant automation.

Table 2- 1 Standard CPUs

CPU	Performance segment	PROFIBUS interfaces	PROFINET IO RT/IRT interfaces	PROFINET IO RT interface	PROFINET basic functionality	Work memory	Processing time for bit operations
CPU 1511-1 PN	Standard CPU for small to mid-range applications	--	1	--	--	1.15 MB	60 ns
CPU 1513-1 PN	Standard CPU for mid-range applications	--	1	--	--	1.8 MB	40 ns
CPU 1515-2 PN	Standard CPU for mid-range to large applications	--	1	1	--	3.5 MB	30 ns
CPU 1516-3 PN/DP	Standard CPU for high-end applications and communication tasks	1	1	1	--	6 MB	10 ns
CPU 1517-3 PN/DP	Standard CPU for high-end applications and communication tasks	1	1	1	--	10 MB	2 ns
CPU 1518-4 PN/DP CPU 1518-4 PN/DP MFP	Standard CPU for high-performance applications, demanding communication tasks and very short reaction times	1	1	1	1	24 MB	1 ns

Table 2- 2 Compact CPUs

CPU	Performance segment	PROFIBUS interfaces	PROFINET IO RT/IRT interfaces	PROFINET IO RT interface	PROFINET basic functionality	Work memory	Processing time for bit operations
CPU 1511C-1 PN	Compact CPU for small to mid-range applications	--	1	--	--	1.175 MB	60 ns
CPU 1512C-1 PN	Compact CPU for mid-range applications	--	1	--	--	1.25 MB	48 ns

Table 2- 3 Fail-safe CPUs

CPU	Performance segment	PROFIBUS interfaces	PROFINET IO RT/IRT interfaces	PROFINET IO RT interface	PROFINET basic functionality	Work memory	Processing time for bit operations
CPU 1511F-1 PN	Fail-safe CPU for small to mid-range applications	--	1	--	--	1.225 MB	60 ns
CPU 1511TF-1 PN	Fail-safe technology CPU for small to mid-range applications	--	1	--	--	1.225 MB	60 ns
CPU 1513F-1 PN	Fail-safe CPU for mid-range applications	--	1	--	--	1.95 MB	40 ns
CPU 1515F-2 PN	Fail-safe CPU for mid-range to large applications	--	1	1	--	3.75 MB	30 ns
CPU 1515TF-2 PN	Fail-safe technology CPU for demanding applications and communication tasks	--	1	1	--	3.75 MB	30 ns
CPU 1516F-3 PN/DP	Fail-safe CPU for demanding applications and communication tasks	1	1	1	--	6.5 MB	10 ns
CPU 1516TF-3 PN/DP	Fail-safe technology CPU for demanding applications and communication tasks	1	1	1	--	6.5 MB	10 ns
CPU 1517F-3 PN/DP	Fail-safe CPU for demanding applications and communication tasks	1	1	1	--	11 MB	2 ns
CPU 1517TF-3 PN/DP	Fail-safe technology CPU for demanding applications and communication tasks	1	1	1	--	11 MB	2 ns
CPU 1518F-4 PN/DP CPU 1518F-4 PN/DP MFP	Fail-safe CPU for high-performance applications, demanding communication tasks and very short reaction times	1	1	1	1	26 MB	1 ns

2.1 Applications of the S7-1500 CPU

Table 2- 4 Technology CPUs

CPU	Performance segment	PROFIBUS interfaces	PROFINET IO RT/IRT interfaces	PROFINET IO RT interface	PROFINET basic functionality	Work memory	Processing time for bit operations
CPU 1511T-1 PN	Technology CPU for small to mid-range applications	--	1	--	--	1.225 MB	60 ns
CPU 1515T-2 PN	Technology CPU for mid-range to large applications	--	1	1	--	3.75 MB	30 ns
CPU 1516T-3 PN/DP	Technology CPU for high-end applications and communication tasks	1	1	1	--	6.5 MB	10 ns
CPU 1517T-3 PN/DP	Technology CPU for high-end applications and communication tasks	1	1	1	--	11 MB	2 ns
CPU 1511TF-1 PN CPU 1515TF-2 PN CPU 1516TF-3 PN/DP CPU 1517TF-3 PN/DP	These CPUs are described in the fail-safe CPUs						

Performance segments of compact CPUs

The compact CPUs can be used for smaller to mid-range applications and have an integrated analog and digital on-board I/O module as well as integrated technology functions. The following table shows the specific properties of the Compact CPUs.

	CPU 1511C-1 PN	CPU 1512C-1 PN
Integrated analog inputs/outputs	5 inputs/2 outputs	5 inputs/2 outputs
Integrated digital inputs/outputs	16 inputs/16 outputs	32 inputs/32 outputs
High-speed counters	6	6
Frequency meter	6 (max. 100 kHz)	6 (max. 100 kHz)
Period duration measurement	6 channels	6 channels
Pulse width modulation (PWM output)	Max. 4 (up to 100 kHz)	Max. 4 (up to 100 kHz)
Pulse Train Output (PTO output)	Max. 4 (up to 100 kHz)	Max. 4 (up to 100 kHz)
Frequency output	Up to 100 kHz	Up to 100 kHz

## Integrated Motion Control technology functions

All CPUs of SIMATIC S7-1500 support Motion Control technology functions. STEP 7 offers Motion Control instructions standardized according to PLCOpen for configuring and connecting a drive to the CPU.

S7-1500 Motion Control supports the following technology objects:

- Speed-controlled axes
- Positioning axes
- Synchronous axes
- External encoders
- Output cams
- Cam tracks
- Measuring inputs

The technology CPUs of the SIMATIC S7-1500 offer enhanced Motion Control functions:

- Advanced synchronization functions
  - Synchronization with specification of the synchronous position
  - Actual value coupling
  - Shifting of the master value at following axis
  - Camming
- Up to 4 encoders or measuring systems as actual position for position control

The technology CPUs of the SIMATIC S7-1500 additionally support the following technology objects: – Cam – Kinematics

- Cam
- Kinematics
- Controlling of kinematics, such as
  - Cartesian portals
  - Roller pickers
  - Delta pickers
  - SCARA

Due to the supported technology functions, the S7-1500T CPUs are suitable for controlling packaging machines, converting applications, assembly automation, etc.

## Additional integrated technology functions

For effective commissioning, diagnostics and fast optimization of drives and controls, the SIMATIC S7-1500 controller family offers extensive trace functions for all CPU tags.

In addition to drive integration, the SIMATIC S7-1500 has a PID compact closed-loop controller; easy-to-configure blocks allow automatic optimization of the controller parameters for optimized control quality.

## Other technology functions

Technology modules also implement functions such as high-speed counting, position detection, measuring functions and pulse generators (PTO, PWM and frequency output). For compact CPU 1511C-1 PN and CPU 1512C-1 PN CPUs, these functions are already integrated and can be implemented without additional technology modules.

SIWAREX is a versatile and flexible weighing module which you can use as a static scale for operation.

## Security Integrated

In conjunction with STEP 7, each CPU offers password-based know-how protection against unauthorized reading out or modification of the program blocks.

Copy protection provides reliable protection against unauthorized reproduction of program blocks. With copy protection, individual blocks on the SIMATIC memory card can be tied to its serial number so that the block can only be run if the configured memory card is inserted into the CPU.

In addition, you can assign various access rights to different user groups in the controller using four different authorization levels.

Improved manipulation protection allows changed or unauthorized transfers of engineering data to be detected by the controller.

The use of an Ethernet CP (CP 1543-1) provides you with additional access protection through a firewall or possibilities to establish secure VPN connections.

## Safety Integrated

The fail-safe CPUs are intended for users who want to implement demanding standard and fail-safe applications both centrally and decentrally.

These fail-safe CPUs allow the processing of standard and safety programs on a single CPU. This allows fail-safe data to be evaluated in the standard user program. The integration also provides the system advantages and the extensive functionality of SIMATIC for fail-safe applications.

The fail-safe CPUs are certified for use in safety mode up to:

- Safety class (Safety Integrity Level) SIL 3 according to IEC 61508:2010
- Performance Level (PL) e and Category 4 according to ISO 13849-1:2006 or according to EN ISO 13849-1:2008

Additional password protection for F-configuration and F-program is set up for IT security.



## Design and handling

All CPUs of the SIMATIC S7-1500 product series feature a display with plain text information. The display provides the user with information on the order numbers, firmware version, and serial number of all connected modules. In addition, the IP address of the CPU and other network settings can be adapted locally without a programming device. Error messages are immediately shown on the display in plain text. In the case of servicing, plant downtimes are minimized by quick access to diagnostics alarms. Detailed information about this and a multitude of other display functions is available in the SIMATIC S7-1500 Display Simulator ([http://www.automation.siemens.com/salesmaterial-as/interactive-manuals/getting-started\\_simatic-s7-1500/disp\\_tool/start\\_en.html](http://www.automation.siemens.com/salesmaterial-as/interactive-manuals/getting-started_simatic-s7-1500/disp_tool/start_en.html)).

Uniform front connectors for all modules and integrated potential jumpers for flexible formation of potential groups simplifies storage. Additional components such as circuit breakers, relays, etc., can be installed quickly and easily, since a DIN rail is implemented in the rail of the S7-1500. The CPUs of the SIMATIC S7-1500 product series can be expanded centrally and in a modular fashion with signal modules. Space-saving expansion enables flexible adaptation to each application.

The system cabling for digital signal modules enables fast and clear connection to sensors and actuators from the field (fully modular connection consisting of front connector modules, connection cables and I/O modules), as well as easy wiring inside the control cabinet (flexible connection consisting of front connectors with assembled single conductors).

## System diagnostics and alarms

Integrated system diagnostics is activated by default for the CPUs. The different types of diagnostics are configured instead of programmed. System diagnostics information is shown uniformly and in plain text on the display of the CPU, in STEP 7, on the HMI and on the Web server, even for alarms related to drives. This information is available in RUN mode, but also in STOP mode of the CPU. The diagnostic information is updated automatically when you configure new hardware components.

The CPU is available as a central interrupt server in up to three project languages. The HMI takes over the display in the project languages specified for the CPU. If you require message texts in additional languages, you can load these via the configured connection to your HMI. The CPU, STEP 7 and your HMI guarantee data consistency without additional engineering steps. The maintenance work is easier.

## 2.2 Hardware properties

### Article number

6ES7511-1AK02-0AB0

### View of the module

The following figure shows a CPU 1511-1 PN.



Figure 2-1 CPU 1511-1 PN

---

### Note

#### Protective film

Note that a protective film is attached to the display of the CPU when shipped from the factory. Remove the protective film if necessary.

---

## Properties

CPU 1511-1 PN has the following technical properties:

Property	Description	Additional information
<b>CPU display</b>	<p>All CPUs of the SIMATIC S7-1500 product series feature a display with plain text information. The display provides information on order numbers, firmware version and serial numbers of all connected modules. In addition, you can set the IP address of the CPU and carry out further network settings. The display shows occurring error messages directly in plain text.</p> <p>In addition to the functions listed here, a multitude of other functions that are described in the SIMATIC S7-1500 Display Simulator are shown on the display.</p>	<ul style="list-style-type: none"> <li>S7-1500, ET 200MP system manual (<a href="http://support.automation.siemens.com/WW/view/en/59191792">http://support.automation.siemens.com/WW/view/en/59191792</a>)</li> <li>SIMATIC S7-1500 Display Simulator (<a href="http://www.automation.siemens.com/salesmaterial-as/interactive-manuals/getting-started_simatic-s7-1500/disp_tool/start_en.html">http://www.automation.siemens.com/salesmaterial-as/interactive-manuals/getting-started_simatic-s7-1500/disp_tool/start_en.html</a>)</li> </ul>
<b>Supply voltage</b>	The 24 V DC supply voltage is supplied via a 4-pole connection plug that is located at the front of the CPU.	<ul style="list-style-type: none"> <li>Chapter Connecting up (Page 29)</li> <li>S7-1500, ET 200MP system manual (<a href="http://support.automation.siemens.com/WW/view/en/59191792">http://support.automation.siemens.com/WW/view/en/59191792</a>)</li> </ul>
<b>PROFINET IO</b>		
PROFINET interface (X1 P1 R and X1 P2 R)	The interface has two ports. In addition to basic PROFINET functionality, its also supports PROFINET IO RT (real time) and IRT (isochronous real time).	PROFINET function manual ( <a href="https://support.industry.siemens.com/cs/ww/en/view/49948856">https://support.industry.siemens.com/cs/ww/en/view/49948856</a> )
Operation of the CPU as <ul style="list-style-type: none"> <li>IO controller</li> <li>I-device</li> </ul>	<ul style="list-style-type: none"> <li><b>IO controller:</b> As an IO controller the CPU addresses the connected IO devices</li> <li><b>I-device:</b> As an I-device (intelligent IO device) the CPU is assigned to a higher-level IO controller and is used in the process as an intelligent pre-processing unit of sub-processes</li> </ul>	

## Accessories

You can find information on "Accessories/spare parts" in the S7-1500, ET 200MP system manual (<http://support.automation.siemens.com/WW/view/en/59191792>).

## 2.3 Firmware functions

### Functions

The CPU 1511-1 PN supports the following firmware functions:

Function	Description	Additional information
<b>Integrated system diagnostics</b>	The system automatically generates the messages for the system diagnostics and outputs these messages via a programming device/PC, HMI device, the Web server or the integrated display. System diagnostics information is also available when the CPU is in STOP mode.	Diagnostics function manual ( <a href="https://support.industry.siemens.com/cs/ww/en/view/59193560">https://support.industry.siemens.com/cs/ww/en/view/59193560</a> )
<b>Integrated Web server</b>	The Web server lets you access the CPU data by means of a network. Evaluations, diagnostics, and modifications are thus possible over long distances. Monitoring and evaluation is possible without STEP 7; all you need is a Web browser. Make sure that you take appropriate measures (e.g. limiting network access, using firewalls) to protect the CPU from being compromised.	<ul style="list-style-type: none"> <li>• Web server function manual (<a href="https://support.industry.siemens.com/cs/ww/en/view/59192926">https://support.industry.siemens.com/cs/ww/en/view/59192926</a>)</li> <li>• Security with SIMATIC S7 controllers system manual (<a href="https://support.industry.siemens.com/cs/ww/en/view/90885010">https://support.industry.siemens.com/cs/ww/en/view/90885010</a>)</li> </ul>
<b>Integrated trace functionality</b>	Trace functionality supports you in troubleshooting and/or optimizing the user program.  You record device tags and evaluate the recordings with the trace and logic analyzer function. Tags are, for example, drive parameters or system and user tags of a CPU.  The device saves the recordings. You can read out and permanently save the recordings with the configuration system (ES), if required. The trace and logic analyzer function is therefore suitable for monitoring highly dynamic processes.  The trace record can also be displayed through the Web server.	Using the trace and logic analyzer function manual ( <a href="https://support.industry.siemens.com/cs/ww/en/view/64897128">https://support.industry.siemens.com/cs/ww/en/view/64897128</a> )
<b>OPC UA</b>	With OPC UA, you can exchange data via an open and manufacturer-neutral communication protocol. The CPU can act as OPC UA DA server. The CPU as OPC UA server can communicate with OPC UA clients. The OPC UA Companion Specification allows methods to be specified uniformly and independently of the manufacturer. Using these specified methods, you can easily integrate devices from various manufacturers into your plants and production processes.	Communication function manual ( <a href="https://support.industry.siemens.com/cs/ww/en/view/59192925">https://support.industry.siemens.com/cs/ww/en/view/59192925</a> )
<b>Configuration control</b>	You can use configuration control to operate different real hardware configurations with a configured maximum configuration of the S7-1500 automation system/ET 200MP distributed I/O system. This means that, in series machine manufacturing in particular, you have the option of operating/configuring different configuration variants of a machine with a single project.	S7-1500, ET 200MP system manual ( <a href="https://support.industry.siemens.com/cs/ww/en/view/59191792">https://support.industry.siemens.com/cs/ww/en/view/59191792</a> )

Function	Description	Additional information
<b>PROFINET IO</b>		
RT (real time)	RT prioritizes PROFINET IO telegrams over standard telegrams. This ensures the required determinism in the automation technology. In this process the data is transferred via prioritized Ethernet telegrams.	PROFINET function manual ( <a href="https://support.industry.siemens.com/cs/ww/en/view/49948856">https://support.industry.siemens.com/cs/ww/en/view/49948856</a> )
IRT (isochronous real time)	A reserved bandwidth within the send clock is available for IRT data. The reserved bandwidth ensures that the IRT data can be transmitted in time-synchronized intervals, unaffected by other high network loading (e.g. TCP/IP communication or additional real-time communication). Update times with maximum determinism can be realized through IRT. Isochronous applications are possible with IRT.	
Isochronous mode	The Isochronous mode system property acquires measured values and process data and processes the signals in a fixed system clock. Isochronous mode thus contributes to high control quality and hence to greater manufacturing precision. Isochronous mode reduces possible fluctuations of the process reaction times to a minimum. Time-assured processing makes higher machine cycles possible.	
MRP (Media Redundancy Protocol)	It is possible to establish redundant networks via the Media Redundancy Protocol. Redundant transmission links (ring topology) ensure that an alternative communication path is made available if a transmission link fails. The PROFINET devices that are part of this redundant network form an MRP domain. RT operation is possible with the use of MRP.	
MRPD (Media Redundancy with Planned Duplication)	The advantage of the MRP extension MRPD is that, in the event of a failure of a device or a line in the ring, all other devices continue to be supplied with IO data without interruption and with short update times. MRPD is based on IRT and MRP. To realize media redundancy with short update times, the PROFINET devices participating in the ring send their data in both directions. The devices receive this data at both ring ports so that there is no reconfiguration time.	
Shared device	The "Shared device" function allows you to divide the modules or submodules of an IO device up among different IO controllers. Numerous IO controllers are often used in larger or widely distributed systems. Without the "Shared device" function, each I/O module of an IO device is assigned to the same IO controller. If sensors that are physically close to each other must provide data to different IO controllers, several IO devices are required. The "Shared device" function allows the modules or submodules of an IO device to be divided up among different IO controllers, thus allowing flexible automation concepts. You can, for example, combine I/O modules that are physically close to each other in one IO device.	

Function	Description	Additional information
PROFenergy	<p>PROFenergy is a PROFINET-based data interface for switching off consumers centrally and with full coordination during pause times regardless of the manufacturer or device type. Through this, the process should only be provided with the energy that is absolutely required. The majority of the energy is saved by the process; the PROFINET device itself only contributes a few watts of savings potential.</p>	
<b>Integrated technology</b>		
Motion Control	<p>S7-1500 CPUs support the controlled positioning and traveling of axes via S7-1500 Motion Control functions by means of the following technology objects:</p> <p>Speed-controlled axes, positioning axes, synchronized axes, external encoders, cams, cam tracks and measuring inputs.</p> <ul style="list-style-type: none"> <li>• Speed-controlled axis for controlling a drive with speed specification</li> <li>• Positioning axis for position-controlled positioning of a drive</li> <li>• Synchronous axis to interconnect with a master value. The axis is synchronized to the master axis position.</li> <li>• External encoder for detecting the actual position of an encoder and its use as a master value for synchronous operation</li> <li>• Cams, cam track for position-dependent generation of switching signals</li> <li>• Measuring input for fast, accurate and event-dependent sensing of actual positions</li> </ul>	<p>S7-1500 Motion Control function manual  <a href="https://support.industry.siemens.com/cs/ww/en/view/109749262">https://support.industry.siemens.com/cs/ww/en/view/109749262</a></p>
Integrated closed-loop control functionality	<ul style="list-style-type: none"> <li>• PID Compact (continuous PID controller)</li> <li>• PID 3Step (step controller for integrating actuators)</li> <li>• PID Temp (temperature controller for heating and cooling with two separate actuators)</li> </ul>	<p>PID control function manual  <a href="https://support.industry.siemens.com/cs/ww/en/view/108210036">https://support.industry.siemens.com/cs/ww/en/view/108210036</a></p>

Function	Description	Additional information
<b>Integrated safety</b>		
Know-how protection	The know-how protection protects user blocks against unauthorized access and modifications.	S7-1500, ET 200MP system manual ( <a href="https://support.industry.siemens.com/cs/ww/en/view/59191792">https://support.industry.siemens.com/cs/ww/en/view/59191792</a> )
Copy protection	Copy protection links user blocks to the serial number of the SIMATIC memory card or to the serial number of the CPU. User programs cannot run without the corresponding SIMATIC memory card or CPU.	
Access protection	You can use authorization levels to assign separate rights to different users.	
Integrity protection	The CPUs dispose of integrity protection by default. Integrity protection identifies possible manipulations of engineering data on the SIMATIC memory card or during data transfer between TIA Portal and CPU.  Integrity protection also checks the communication from a SIMATIC HMI system to the CPU for possible manipulations of engineering data.  If integrity protection identifies the manipulation of engineering data, the user receives a corresponding message.	
Password provider	As an alternative to manual password input you can connect a password provider to STEP 7. A password provider offers the following advantages: <ul style="list-style-type: none"> <li>• Convenient handling of passwords. STEP 7 reads the password automatically for the blocks. This saves you time.</li> <li>• Optimum block protection because the users do not know the password itself.</li> </ul>	

## 2.4 Operating and display elements

### 2.4.1 Front view of the CPU with closed front panel

The following figure shows the front view of the CPU 1511-1 PN.

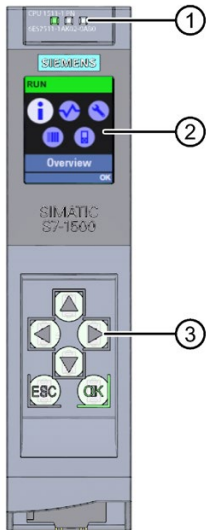

- ① LEDs for the current operating mode and diagnostics status of the CPU
- ② Display
- ③ Operator control buttons

Figure 2-2 View of the CPU 1511-1 PN (with front panel) - front

---

#### Note

##### Temperature range for display

To increase its service life, the display switches off at a temperature below the permitted operating temperature of the device. When the display cools down, it automatically switches itself on again. When the display is switched off, the LEDs continue to show the status of the CPU.

For more information on the temperatures at which the display switches itself on and off, refer to the Technical specifications (Page 36).

---



## Removing and fitting the front panel or the display

You can remove and fit the front panel or the display during operation.

### WARNING

#### Personal injury and damage to property may occur

If you remove or attach the front panel of an S7-1500 automation system during operation, personal injury or damage to property can occur in zone 2 hazardous areas.

Before you remove or fit the front panel, always switch off the power supply to the S7-1500 automation system in hazardous area zone 2. The CPU maintains its operating mode.

## Locking the front panel

You can lock the front panel to protect your CPU against unauthorized access.

You can attach a security seal or a padlock with a diameter of 3 mm to the front panel.

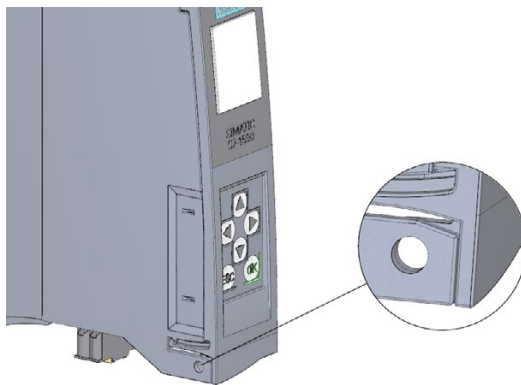

Figure 2-3 Locking latch on the CPU

In addition to the mechanical lock, you can also block access to a password-protected CPU on the display (local lock) and assign a password for the display. You can find additional information on the display, configurable protection levels and local locks in the S7-1500, ET 200MP (<http://support.automation.siemens.com/WW/view/en/59191792>) system manual.

## Reference

You will find detailed information on the individual display options, a training course and a simulation of the available menu commands in the SIMATIC S7-1500 Display Simulator ([http://www.automation.siemens.com/salesmaterial-as/interactive-manuals/getting-started\\_simatic-s7-1500/disp\\_tool/start\\_en.html](http://www.automation.siemens.com/salesmaterial-as/interactive-manuals/getting-started_simatic-s7-1500/disp_tool/start_en.html)).

### 2.4.2 Front view of the CPU without front panel and view from below

The following figure shows the operator controls and connection elements of the CPU 1511-1 PN.

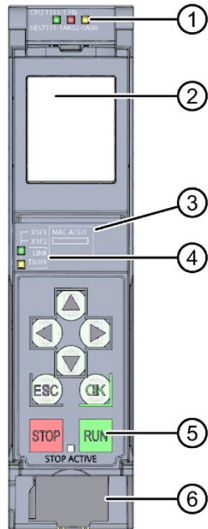

- ① LEDs for the current operating mode and diagnostic status of the CPU
- ② Display
- ③ MAC address
- ④ LED displays for the 2 ports of the PROFINET interface X1
- ⑤ Operating modes with "STOP ACTIVE" LED
- ⑥ Connector for power supply

Figure 2-4 View of the CPU 1511-1 PN (without front panel) – front

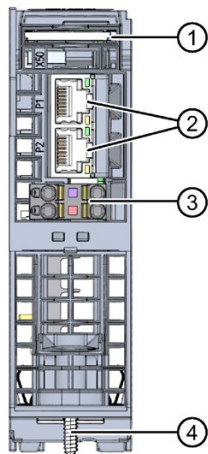

- ① Slot for the SIMATIC memory card
- ② PROFINET IO interface (X1) with 2 ports
- ③ Connection for supply voltage
- ④ Fixing screw

Figure 2-5 View of the CPU 1511-1 PN – bottom

### 2.4.3 Rear view of the CPU

The following figure shows the connection elements on the back of the CPU 1511-1 PN.

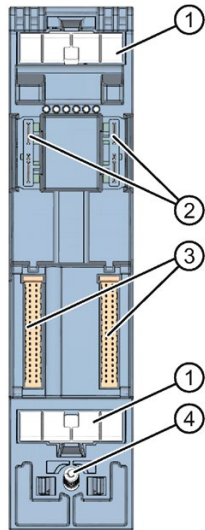

- ① Shield contact surface
- ② Plug-in connection for power supply
- ③ Plug-in connection for backplane bus
- ④ Fastening screw

Figure 2-6 View of the CPU 1511-1 PN - rear

## 2.5 Operating mode buttons

You use the operating mode buttons to set the operating mode of the CPU.

The following table shows the meaning of the corresponding operation of the operating mode buttons.

Table 2- 5 Meaning of the operating mode buttons

Operation of the operating mode buttons	Meaning	Explanation
RUN	RUN mode	The CPU is executing the user program.
STOP	STOP mode	The user program is not being executed. (STOP ACTIVE LED lights up).
<p>MRES</p> <ol style="list-style-type: none"> <li>Press the operating mode button STOP. Result: The RUN/STOP LED lights up yellow.</li> <li>Press the operating mode button STOP until the RUN/STOP LED lights up for the 2nd time and remains continuously lit (this takes three seconds). After this, release the button.</li> <li>Press the operating mode button STOP again within the next three seconds.</li> </ol>	<p>Manual memory reset (with inserted SIMATIC memory card) or Reset to factory settings (without inserted SIMATIC memory card):</p>	<p>The CPU executes memory reset.  or The CPU is reset to its factory settings. You can find additional information in the S7-1500/ET 200MP system manual (<a href="https://support.industry.siemens.com/cs/ww/en/view/59191792">https://support.industry.siemens.com/cs/ww/en/view/59191792</a>).</p>

## Connecting up

This section provides information on the terminal assignment of the individual interfaces and the block diagram of the CPU 1511-1 PN.

### 24 V DC supply voltage (X80)

The connector for the power supply is plugged in when the CPU ships from the factory.

The following table shows the pin assignment for a 24 V DC power supply.

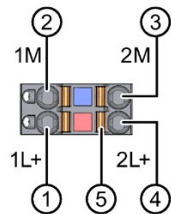

- ① +24 V DC of the supply voltage
- ② Ground of the supply voltage
- ③ Ground of the supply voltage for loop-through (maximum of 10 A permitted)
- ④ +24 V DC of the supply voltage for loop-through (maximum of 10 A permitted)
- ⑤ Spring opener (one spring opener per terminal)

Bridged internally:

- ① and ④
- ② and ③

Figure 3-1 Supply voltage connection

If the CPU is supplied by a system power supply, it is not necessary to connect the 24 V supply.

### PROFINET interface X1 with 2-port switch (X1 P1 R and X1 P2 R)

The assignment corresponds to the Ethernet standard for an RJ45 plug.

- When autonegotiation is deactivated, the RJ45 socket is allocated as a switch (MDI-X).
- When autonegotiation is activated, autocrossing is in effect and the RJ45 socket is allocated either as data terminal equipment (MDI) or a switch (MDI-X).

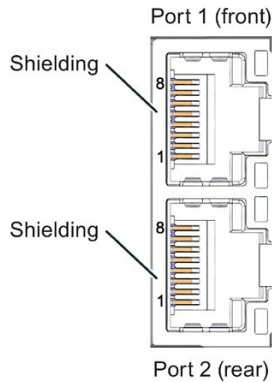

Figure 3-2 PROFINET ports

---

#### Note

You need a screwdriver (max. blade width 2.5 mm) to remove the PROFINET plug.

---

#### Reference

You can find additional information on the topics of "Connecting the CPU" and "Accessories/spare parts" in the S7-1500, ET 200MP (<http://support.automation.siemens.com/WW/view/en/59191792>) system manual.

## Assignment of the MAC addresses

The CPU 1511-1 PN has a PROFINET interface with two ports. The PROFINET interface itself has a MAC address, and each of the two PROFINET ports has its own MAC address. The CPU 1511-1 PN therefore has three MAC addresses in total.

The MAC addresses of the PROFINET ports are needed for the LLDP protocol, for example for the neighborhood discovery function.

The number range of the MAC addresses is sequential. The first and last MAC address are lasered on the rating plate on the right side of each CPU 1511-1 PN.

The table below shows how the MAC addresses are assigned.

Table 3- 1 Assignment of the MAC addresses

	<b>Assignment</b>	<b>Labeling</b>
<b>MAC address 1</b>	PROFINET interface X1 (visible in STEP 7 for accessible devices)	<ul style="list-style-type: none"> <li>• Front, lasered</li> <li>• Right side, lasered (start of number range)</li> </ul>
<b>MAC address 2</b>	Port X1 P1 R (required for LLDP, for example)	<ul style="list-style-type: none"> <li>• Front and right side, not lasered</li> </ul>
<b>MAC address 3</b>	Port X1 P2 R (required for LLDP, for example)	<ul style="list-style-type: none"> <li>• Front, not lasered</li> <li>• Right side, lasered (end of number range)</li> </ul>

**Block diagram**

The following figure shows the block diagram of the CPU 1511-1 PN.

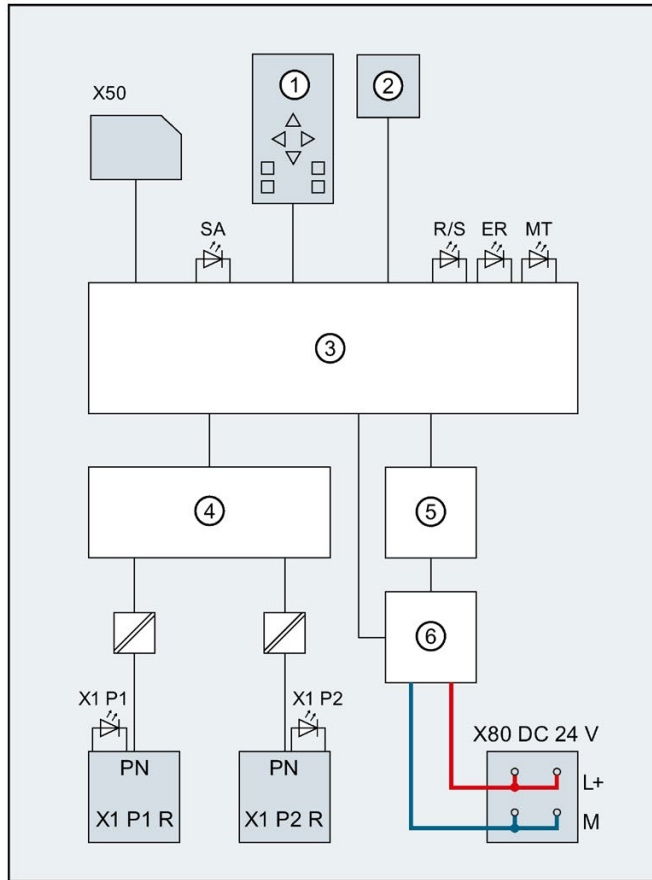

①	CPU with control and operating mode buttons	X80 24 V DC	Infeed of supply voltage
②	Display	L+	24 V DC supply voltage
③	Electronics	M	Ground
④	PROFINET 2-port switch	SF	STOP ACTIVE LED (yellow)
⑤	Backplane bus interface	R/S	RUN/STOP LED (yellow/green)
⑥	Internal supply voltage	ER	ERROR LED (red)
PN X1 P1 R	PROFINET interface X1 Port 1	MT	MAINT LED (yellow)
PN X1 P2 R	PROFINET interface X1 Port 2	X1 P1, X1 P2	LED Link TX/RX
X50	SIMATIC memory card		

Figure 3-3 Block diagram CPU 1511-1 PN



# Interrupts, error messages, diagnostics and system alarms

# 4

The status and error displays of the CPU 1511-1 PN are described below.

You will find additional information on "Interrupts" in the STEP 7 online help.

You can find additional information on the topics of "Diagnostics" and "System alarms" in the Diagnostics (<http://support.automation.siemens.com/WW/view/en/59192926>) function manual.

## 4.1 Status and error display of the CPU

### LED display

The figure below shows the CPU 1511-1 PN LEDs.

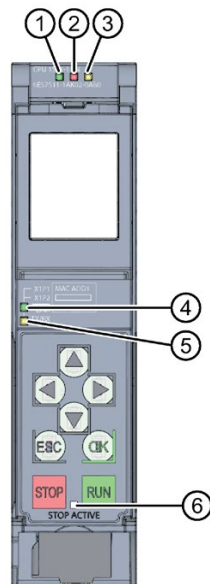

- ① RUN/STOP LED (yellow/green LED)
- ② ERROR LED (red LED)
- ③ MAINT LED (yellow LED)
- ④ LINK RX/TX LED for port X1 P1 (yellow/green LED)
- ⑤ LINK RX/TX LED for port X1 P2 (yellow/green LED)
- ⑥ STOP ACTIVE-LED (yellow LED)







































Figure 4-1 LED display of the CPU 1511-1 PN (without front panel)



4.1 Status and error display of the CPU

**Meaning of the RUN/STOP, ERROR and MAINT LEDs**

The CPU 1511-1 PN has three LEDs to signal the current operating status and diagnostics status. The following table shows the meaning of the various combinations of colors for the RUN/STOP, ERROR and MAINT LEDs.

Table 4- 1 Meaning of the LEDs





RUN/STOP LED	ERROR LED	MAINT LED	Meaning
 LED off	 LED off	 LED off	Missing or insufficient power supply on the CPU.
 LED off	 LED flashes red	 LED off	An error has occurred.
 LED lit green	 LED off	 LED off	CPU is in RUN mode.
 LED lit green	 LED flashes red	 LED off	A diagnostics event is pending.
 LED lit green	 LED off	 LED lit yellow	Maintenance demanded for the plant. The affected hardware must be checked/replaced within a short period of time.
			Active Force job
			PROFenergy pause
 LED lit green	 LED off	 LED flashes yellow	Maintenance required for the plant. The affected hardware must be checked/replaced within a foreseeable period of time.
			Bad configuration
 LED lit green	 LED flashes red	 LED off	An error has occurred.
 LED lit yellow	 LED flashes red	 LED off	
 LED lit yellow	 LED off	 LED flashes yellow	Firmware update successfully completed.
 LED lit yellow	 LED off	 LED off	CPU is in STOP mode.
 LED lit yellow	 LED flashes red	 LED flashes yellow	The program on the SIMATIC memory card is causing an error.
			CPU defective
 LED flashes yellow	 LED off	 LED off	CPU is performing internal activities during STOP, e.g. startup after STOP.
			Download of the user program from the SIMATIC memory card
			CPU carries out a program with active breakpoint.
 LED flashes yellow/green	 LED off	 LED off	Startup (transition from RUN → STOP)

RUN/STOP LED	ERROR LED	MAINT LED	Meaning
 LED flashes yellow/green	 LED flashes red	 LED flashes yellow	Startup (CPU booting)
			Test of LEDs during startup, inserting a module.
			LED flashing test

### Meaning of LINK RX/TX LED

Each port has a LINK RX/TX LED. The table below shows the various "LED scenarios" of the ports for the CPU 1511-1 PN.



Table 4- 2 Meaning of the LEDs

LINK TX/RX LED	Meaning
 LED off	There is no Ethernet connection between the PROFINET interface of the PROFINET device and the communication partner. No data is currently being sent/received via the PROFINET interface. There is no LINK connection.
 LED flashes green	The "LED flashing test" is being performed.
 LED lit green	There is an Ethernet connection between the PROFINET interface of your PROFINET device and a communication partner.
 LED flickers yellow	Data is currently being received from or sent to a communications partner on Ethernet via the PROFINET interface of the PROFINET device.

### Meaning of the STOP ACTIVE LED

The following table shows the meaning of the STOP ACTIVE LED for the CPU 1511-1 PN.

Table 4- 3 Meaning of the LEDs

STOP ACTIVE LED	Meaning
 LED lit yellow	The CPU is switched to "STOP" mode using the STOP button. <ul style="list-style-type: none"> <li>As long as the STOP ACTIVE LED is lit up, switching the CPU to RUN mode is only possible using the RUN button.</li> <li>The CPU can then no longer be set to RUN mode via the display operation or via online functions. The state of the buttons is retained at power-off. If the CPU does not start up automatically after a power-on, you have to keep the STOP button pressed during start-up until the STOP ACTIVE LED is activated.</li> <li>If an automatic start-up is to be reliably prevented after a power-up, the STOP button has to be kept pressed during the start-up of the CPU until the STOP ACTIVE LED is activated.</li> </ul>
 LED off	<ul style="list-style-type: none"> <li>The CPU is set to "STOP" mode using the display or programming device and not with the STOP button on the device.</li> <li>The CPU is in RUN mode.</li> </ul>

## Technical specifications

<b>Article number</b>	<b>6ES7511-1AK02-0AB0</b>
<b>General information</b>	
Product type designation	CPU 1511-1 PN
HW functional status	FS01
Firmware version	V2.5
<b>Engineering with</b>	
<ul style="list-style-type: none"> <li>STEP 7 TIA Portal configurable/integrated as of version</li> </ul>	V15
<b>Configuration control</b>	
via dataset	Yes
<b>Display</b>	
Screen diagonal [cm]	3.45 cm
<b>Control elements</b>	
Number of keys	8
Mode buttons	2
<b>Supply voltage</b>	
Type of supply voltage	24 V DC
permissible range, lower limit (DC)	19.2 V
permissible range, upper limit (DC)	28.8 V
Reverse polarity protection	Yes
<b>Mains buffering</b>	
<ul style="list-style-type: none"> <li>Mains/voltage failure stored energy time</li> </ul>	5 ms
<ul style="list-style-type: none"> <li>Repeat rate, min.</li> </ul>	1/s
<b>Input current</b>	
Current consumption (rated value)	0.7 A
Current consumption, max.	0.95 A
Inrush current, max.	1.9 A; Rated value
$I^2t$	0.02 A <sup>2</sup> ·s
<b>Power</b>	
Infeed power to the backplane bus	10 W
Power consumption from the backplane bus (balanced)	5.5 W
<b>Power loss</b>	
Power loss, typ.	5.7 W
<b>Memory</b>	
Number of slots for SIMATIC memory card	1
SIMATIC memory card required	Yes

<b>Article number</b>	<b>6ES7511-1AK02-0AB0</b>
<b>Work memory</b>	
<ul style="list-style-type: none"> <li>integrated (for program)</li> </ul>	150 kbyte
<ul style="list-style-type: none"> <li>integrated (for data)</li> </ul>	1 Mbyte
<b>Load memory</b>	
<ul style="list-style-type: none"> <li>Plug-in (SIMATIC Memory Card), max.</li> </ul>	32 Gbyte
<b>Backup</b>	
<ul style="list-style-type: none"> <li>maintenance-free</li> </ul>	Yes
<b>CPU processing times</b>	
for bit operations, typ.	60 ns
for word operations, typ.	72 ns
for fixed point arithmetic, typ.	96 ns
for floating point arithmetic, typ.	384 ns
<b>CPU-blocks</b>	
Number of elements (total)	2 000; Blocks (OB, FB, FC, DB) and UDTs
<b>DB</b>	
<ul style="list-style-type: none"> <li>Number range</li> </ul>	1 ... 60 999; subdivided into: number range that can be used by the user: 1 ... 59 999, and number range of DBs created via SFC 86: 60 000 ... 60 999
<ul style="list-style-type: none"> <li>Size, max.</li> </ul>	1 Mbyte; For non-optimized block accesses, the max. size of the DB is 64 KB
<b>FB</b>	
<ul style="list-style-type: none"> <li>Number range</li> </ul>	0 ... 65 535
<ul style="list-style-type: none"> <li>Size, max.</li> </ul>	150 kbyte
<b>FC</b>	
<ul style="list-style-type: none"> <li>Number range</li> </ul>	0 ... 65 535
<ul style="list-style-type: none"> <li>Size, max.</li> </ul>	150 kbyte
<b>OB</b>	
<ul style="list-style-type: none"> <li>Size, max.</li> </ul>	150 kbyte
<ul style="list-style-type: none"> <li>Number of free cycle OBs</li> </ul>	100
<ul style="list-style-type: none"> <li>Number of time alarm OBs</li> </ul>	20
<ul style="list-style-type: none"> <li>Number of delay alarm OBs</li> </ul>	20
<ul style="list-style-type: none"> <li>Number of cyclic interrupt OBs</li> </ul>	20; With minimum OB 3x cycle of 500 µs
<ul style="list-style-type: none"> <li>Number of process alarm OBs</li> </ul>	50
<ul style="list-style-type: none"> <li>Number of DPV1 alarm OBs</li> </ul>	3
<ul style="list-style-type: none"> <li>Number of isochronous mode OBs</li> </ul>	1
<ul style="list-style-type: none"> <li>Number of technology synchronous alarm OBs</li> </ul>	2
<ul style="list-style-type: none"> <li>Number of startup OBs</li> </ul>	100

<b>Article number</b>	<b>6ES7511-1AK02-0AB0</b>
<ul style="list-style-type: none"> <li>• Number of asynchronous error OBs</li> <li>• Number of synchronous error OBs</li> <li>• Number of diagnostic alarm OBs</li> </ul>	<p>4</p> <p>2</p> <p>1</p>
<b>Nesting depth</b>	
<ul style="list-style-type: none"> <li>• per priority class</li> </ul>	24
<b>Counters, timers and their retentivity</b>	
<b>S7 counter</b>	
<ul style="list-style-type: none"> <li>• Number</li> </ul>	2 048
<b>Retentivity</b>	
– adjustable	Yes
<b>IEC counter</b>	
<ul style="list-style-type: none"> <li>• Number</li> </ul>	Any (only limited by the main memory)
<b>Retentivity</b>	
– adjustable	Yes
<b>S7 times</b>	
<ul style="list-style-type: none"> <li>• Number</li> </ul>	2 048
<b>Retentivity</b>	
– adjustable	Yes
<b>IEC timer</b>	
<ul style="list-style-type: none"> <li>• Number</li> </ul>	Any (only limited by the main memory)
<b>Retentivity</b>	
– adjustable	Yes
<b>Data areas and their retentivity</b>	
Retentive data area (incl. timers, counters, flags), max.	128 kbyte; In total; available retentive memory for bit memories, timers, counters, DBs, and technology data (axes): 88 KB
Extended retentive data area (incl. timers, counters, flags), max.	1 Mbyte; When using PS 60W 24/48/60V DC HF
<b>Flag</b>	
<ul style="list-style-type: none"> <li>• Number, max.</li> <li>• Number of clock memories</li> </ul>	<p>16 kbyte</p> <p>8; 8 clock memory bits, grouped into one clock memory byte</p>
<b>Data blocks</b>	
<ul style="list-style-type: none"> <li>• Retentivity adjustable</li> <li>• Retentivity preset</li> </ul>	<p>Yes</p> <p>No</p>
<b>Local data</b>	
<ul style="list-style-type: none"> <li>• per priority class, max.</li> </ul>	64 kbyte; max. 16 KB per block

<b>Article number</b>	<b>6ES7511-1AK02-0AB0</b>
<b>Address area</b>	
Number of IO modules	1 024; max. number of modules / submodules
<b>I/O address area</b>	
• Inputs	32 kbyte; All inputs are in the process image
• Outputs	32 kbyte; All outputs are in the process image
<b>per integrated IO subsystem</b>	
– Inputs (volume)	8 kbyte
– Outputs (volume)	8 kbyte
<b>per CM/CP</b>	
– Inputs (volume)	8 kbyte
– Outputs (volume)	8 kbyte
<b>Subprocess images</b>	
• Number of subprocess images, max.	32
<b>Hardware configuration</b>	
Number of distributed IO systems	32; A distributed I/O system is characterized not only by the integration of distributed I/O via PROFINET or PROFIBUS communication modules, but also by the connection of I/O via AS-i master modules or links (e.g. IE/PB-Link)
<b>Number of DP masters</b>	
• Via CM	4; A maximum of 4 CMs/CPs (PROFIBUS, PROFINET, Ethernet) can be inserted in total
<b>Number of IO Controllers</b>	
• integrated	1
• Via CM	4; A maximum of 4 CMs/CPs (PROFIBUS, PROFINET, Ethernet) can be inserted in total
<b>Rack</b>	
• Modules per rack, max.	32; CPU + 31 modules
• Number of lines, max.	1
<b>PtP CM</b>	
• Number of PtP CMs	the number of connectable PtP CMs is only limited by the number of available slots
<b>Time of day</b>	
<b>Clock</b>	
• Type	Hardware clock
• Backup time	6 wk; At 40 °C ambient temperature, typically
• Deviation per day, max.	10 s; Typ.: 2 s
<b>Operating hours counter</b>	
• Number	16

<b>Article number</b>	<b>6ES7511-1AK02-0AB0</b>
<b>Clock synchronization</b>	
<ul style="list-style-type: none"> <li>• supported</li> <li>• in AS, master</li> <li>• in AS, slave</li> <li>• on Ethernet via NTP</li> </ul>	<p>Yes</p> <p>Yes</p> <p>Yes</p> <p>Yes</p>
<b>Interfaces</b>	
Number of PROFINET interfaces	1
<b>1. Interface</b>	
<b>Interface types</b>	
<ul style="list-style-type: none"> <li>• Number of ports</li> <li>• integrated switch</li> <li>• RJ 45 (Ethernet)</li> </ul>	<p>2</p> <p>Yes</p> <p>Yes; X1</p>
<b>Functionality</b>	
<ul style="list-style-type: none"> <li>• IP protocol</li> <li>• PROFINET IO Controller</li> <li>• PROFINET IO Device</li> <li>• SIMATIC communication</li> <li>• Open IE communication</li> <li>• Web server</li> <li>• Media redundancy</li> </ul>	<p>Yes; IPv4</p> <p>Yes</p> <p>Yes</p> <p>Yes</p> <p>Yes</p> <p>Yes</p> <p>Yes; MRP Automanager according to IEC 62439-2 Edition 2.0</p>
<b>PROFINET IO Controller</b>	
<b>Services</b>	
<ul style="list-style-type: none"> <li>– PG/OP communication</li> <li>– S7 routing</li> <li>– Isochronous mode</li> <li>– Open IE communication</li> <li>– IRT</li> <li>– MRP</li> <li>– MRPD</li> <li>– PROFIenergy</li> <li>– Prioritized startup</li> <li>– Number of connectable IO Devices, max.</li> <li>– Of which IO devices with IRT, max.</li> <li>– Number of connectable IO Devices for RT, max.</li> </ul>	<p>Yes</p> <p>Yes</p> <p>Yes</p> <p>Yes</p> <p>Yes</p> <p>Yes; As MRP redundancy manager and/or MRP client; max. number of devices in the ring: 50</p> <p>Yes; Requirement: IRT</p> <p>Yes</p> <p>Yes; Max. 32 PROFINET devices</p> <p>128; In total, up to 256 distributed I/O devices can be connected via AS-i, PROFIBUS or PROFINET</p> <p>64</p> <p>128</p>



Article number	6ES7511-1AK02-0AB0
– of which in line, max.	128
– Number of IO Devices that can be simultaneously activated/deactivated, max.	8; in total across all interfaces
– Number of IO Devices per tool, max.	8
– Updating times	The minimum value of the update time also depends on communication share set for PROFINET IO, on the number of IO devices, and on the quantity of configured user data
<b>Update time for IRT</b>	
– for send cycle of 250 µs	250 µs to 4 ms; Note: In the case of IRT with isochronous mode, the minimum update time of 625 µs of the isochronous OB is decisive
– for send cycle of 500 µs	500 µs to 8 ms; Note: In the case of IRT with isochronous mode, the minimum update time of 625 µs of the isochronous OB is decisive
– for send cycle of 1 ms	1 ms to 16 ms
– for send cycle of 2 ms	2 ms to 32 ms
– for send cycle of 4 ms	4 ms to 64 ms
– With IRT and parameterization of "odd" send cycles	Update time = set "odd" send clock (any multiple of 125 µs: 375 µs, 625 µs ... 3 875 µs)
<b>Update time for RT</b>	
– for send cycle of 250 µs	250 µs to 128 ms
– for send cycle of 500 µs	500 µs to 256 ms
– for send cycle of 1 ms	1 ms to 512 ms
– for send cycle of 2 ms	2 ms to 512 ms
– for send cycle of 4 ms	4 ms to 512 ms
<b>PROFINET IO Device</b>	
<b>Services</b>	
– PG/OP communication	Yes
– S7 routing	Yes
– Isochronous mode	No
– Open IE communication	Yes
– IRT	Yes
– MRP	Yes
– MRPD	Yes; Requirement: IRT
– PROFINergy	Yes
– Shared device	Yes
– Number of IO Controllers with shared device, max.	4
– Asset management record	Yes; Per user program

<b>Article number</b>	<b>6ES7511-1AK02-0AB0</b>
<b>Interface types</b>	
<b>RJ 45 (Ethernet)</b>	
<ul style="list-style-type: none"> <li>• 100 Mbps</li> <li>• Autonegotiation</li> <li>• Autocrossing</li> <li>• Industrial Ethernet status LED</li> </ul>	<p>Yes</p> <p>Yes</p> <p>Yes</p> <p>Yes</p>
<b>Protocols</b>	
<b>Number of connections</b>	
<ul style="list-style-type: none"> <li>• Number of connections, max.</li> <li>• Number of connections reserved for ES/HMI/web</li> <li>• Number of connections via integrated interfaces</li> <li>• Number of S7 routing paths</li> </ul>	<p>96; via integrated interfaces of the CPU and connected CPs / CMs</p> <p>10</p> <p>64</p> <p>16</p>
<b>PROFINET IO Controller</b>	
<b>Services</b>	
<ul style="list-style-type: none"> <li>– PG/OP communication</li> <li>– S7 routing</li> <li>– Isochronous mode</li> <li>– Open IE communication</li> <li>– IRT</li> <li>– MRP</li> <li>– MRPD</li> <li>– PROFINergy</li> <li>– Prioritized startup</li> <li>– Number of connectable IO Devices, max.</li> <li>– Of which IO devices with IRT, max.</li> <li>– Number of connectable IO Devices for RT, max.</li> <li>– of which in line, max.</li> <li>– Number of IO Devices that can be simultaneously activated/deactivated, max.</li> <li>– Number of IO Devices per tool, max.</li> <li>– Updating times</li> </ul>	<p>Yes</p> <p>Yes</p> <p>Yes</p> <p>Yes</p> <p>Yes</p> <p>Yes; As MRP redundancy manager and/or MRP client; max. number of devices in the ring: 50</p> <p>Yes; Requirement: IRT</p> <p>Yes</p> <p>Yes; Max. 32 PROFINET devices</p> <p>128; In total, up to 256 distributed I/O devices can be connected via AS-i, PROFIBUS or PROFINET</p> <p>64</p> <p>128</p> <p>128</p> <p>8; in total across all interfaces</p> <p>8</p> <p>The minimum value of the update time also depends on communication share set for PROFINET IO, on the number of IO devices, and on the quantity of configured user data</p>

<b>Article number</b>	<b>6ES7511-1AK02-0AB0</b>
<b>SIMATIC communication</b>	
<ul style="list-style-type: none"> <li>• S7 communication, as server</li> </ul>	Yes
<ul style="list-style-type: none"> <li>• S7 communication, as client</li> </ul>	Yes
<ul style="list-style-type: none"> <li>• User data per job, max.</li> </ul>	See online help (S7 communication, user data size)
<b>Open IE communication</b>	
<ul style="list-style-type: none"> <li>• TCP/IP <ul style="list-style-type: none"> <li>– Data length, max.</li> <li>– several passive connections per port, supported</li> </ul> </li> </ul>	Yes 64 kbyte Yes
<ul style="list-style-type: none"> <li>• ISO-on-TCP (RFC1006) <ul style="list-style-type: none"> <li>– Data length, max.</li> </ul> </li> </ul>	Yes 64 kbyte
<ul style="list-style-type: none"> <li>• UDP <ul style="list-style-type: none"> <li>– Data length, max.</li> <li>– UDP multicast</li> </ul> </li> </ul>	Yes 2 kbyte; 1 472 bytes for UDP broadcast Yes; Max. 5 multicast circuits
<ul style="list-style-type: none"> <li>• DHCP</li> </ul>	No
<ul style="list-style-type: none"> <li>• SNMP</li> </ul>	Yes
<ul style="list-style-type: none"> <li>• DCP</li> </ul>	Yes
<ul style="list-style-type: none"> <li>• LLDP</li> </ul>	Yes
<b>Web server</b>	
<ul style="list-style-type: none"> <li>• HTTP</li> </ul>	Yes; Standard and user pages
<ul style="list-style-type: none"> <li>• HTTPS</li> </ul>	Yes; Standard and user pages
<b>OPC UA</b>	
<ul style="list-style-type: none"> <li>• Runtime license required</li> </ul>	Yes
<ul style="list-style-type: none"> <li>• OPC UA Server <ul style="list-style-type: none"> <li>– Application authentication</li> <li>– Security policies</li> <li>– User authentication</li> </ul> </li> </ul>	Yes; Data access (read, write, subscribe), method call, custom address space Yes Available security policies: None, Basic128Rsa15, Basic256Rsa15, Basic256Sha256 "anonymous" or by user name & password
<b>Further protocols</b>	
<ul style="list-style-type: none"> <li>• MODBUS</li> </ul>	Yes; MODBUS TCP
<b>Media redundancy</b>	
<ul style="list-style-type: none"> <li>• Switchover time on line break, typ.</li> </ul>	200 ms; For MRP, bumpless for MRPD
<ul style="list-style-type: none"> <li>• Number of stations in the ring, max.</li> </ul>	50

<b>Article number</b>	<b>6ES7511-1AK02-0AB0</b>
<b>Isochronous mode</b>	
Isochronous operation (application synchronized up to terminal)	Yes; With minimum OB 6x cycle of 625 µs
Equidistance	Yes
<b>S7 message functions</b>	
Number of login stations for message functions, max.	32
Program alarms	Yes
Number of configurable program alarms	5 000
Number of simultaneously active program alarms	
• Number of program alarms	300
• Number of alarms for system diagnostics	100
• Number of alarms for motion technology objects	80
<b>Test commissioning functions</b>	
Joint commission (Team Engineering)	Yes; Parallel online access possible for up to 5 engineering systems
Status block	Yes; Up to 8 simultaneously (in total across all ES clients)
Single step	No
Number of breakpoints	8
<b>Status/control</b>	
• Status/control variable	Yes
• Variables	Inputs/outputs, memory bits, DBs, distributed I/Os, timers, counters
• Number of variables, max.	
– of which status variables, max.	200; per job
– of which control variables, max.	200; per job
<b>Forcing</b>	
• Forcing, variables	Peripheral inputs/outputs
• Number of variables, max.	200
<b>Diagnostic buffer</b>	
• present	Yes
• Number of entries, max.	1 000
– of which powerfail-proof	500
<b>Traces</b>	
• Number of configurable Traces	4; Up to 512 KB of data per trace are possible

<b>Article number</b>	<b>6ES7511-1AK02-0AB0</b>
<b>Interrupts/diagnostics/status information</b>	
<b>Diagnostics indication LED</b>	
• RUN/STOP LED	Yes
• ERROR LED	Yes
• MAINT LED	Yes
• STOP ACTIVE LED	Yes
• Connection display LINK TX/RX	Yes
<b>Supported technology objects</b>	
Motion Control	Yes; Note: The number of axes affects the cycle time of the PLC program; selection guide via the TIA Selection Tool or SIZER
• Number of available Motion Control resources for technology objects (except cam disks)	800
• Required Motion Control resources	
– per speed-controlled axis	40
– per positioning axis	80
– per synchronous axis	160
– per external encoder	80
– per output cam	20
– per cam track	160
– per probe	40
• Positioning axis	
– Number of positioning axes at motion control cycle of 4 ms (typical value)	5
– Number of positioning axes at motion control cycle of 8 ms (typical value)	10
<b>Controller</b>	
• PID_Compact	Yes; Universal PID controller with integrated optimization
• PID_3Step	Yes; PID controller with integrated optimization for valves
• PID-Temp	Yes; PID controller with integrated optimization for temperature
<b>Counting and measuring</b>	
• High-speed counter	Yes
<b>Standards, approvals, certificates</b>	
Suitable for safety functions	No

<b>Article number</b>	<b>6ES7511-1AK02-0AB0</b>
<b>Ambient conditions</b>	
<b>Ambient temperature during operation</b>	
<ul style="list-style-type: none"> <li>horizontal installation, min.</li> <li>horizontal installation, max.</li> <li>vertical installation, min.</li> <li>vertical installation, max.</li> </ul>	<p>0 °C</p> <p>60 °C; Display: 50 °C, at an operating temperature of typically 50 °C, the display is switched off</p> <p>0 °C</p> <p>40 °C; Display: 40 °C, at an operating temperature of typically 40 °C, the display is switched off</p>
<b>Ambient temperature during storage/transportation</b>	
<ul style="list-style-type: none"> <li>min.</li> <li>max.</li> </ul>	<p>-40 °C</p> <p>70 °C</p>
<b>Configuration</b>	
<b>Programming</b>	
<b>Programming language</b>	
<ul style="list-style-type: none"> <li>- LAD</li> <li>- FBD</li> <li>- STL</li> <li>- SCL</li> <li>- GRAPH</li> </ul>	<p>Yes</p> <p>Yes</p> <p>Yes</p> <p>Yes</p> <p>Yes</p>
<b>Know-how protection</b>	
<ul style="list-style-type: none"> <li>User program protection/password protection</li> <li>Copy protection</li> <li>Block protection</li> </ul>	<p>Yes</p> <p>Yes</p> <p>Yes</p>
<b>Access protection</b>	
<ul style="list-style-type: none"> <li>Password for display</li> <li>Protection level: Write protection</li> <li>Protection level: Read/write protection</li> <li>Protection level: Complete protection</li> </ul>	<p>Yes</p> <p>Yes</p> <p>Yes</p> <p>Yes</p>
<b>Cycle time monitoring</b>	
<ul style="list-style-type: none"> <li>lower limit</li> <li>upper limit</li> </ul>	<p>adjustable minimum cycle time</p> <p>adjustable maximum cycle time</p>
<b>Dimensions</b>	
Width	35 mm
Height	147 mm
Depth	129 mm
<b>Weights</b>	
Weight, approx.	405 g

## **General technical specifications**

You can find information on the general technical specifications, such as standards and approvals, electromagnetic compatibility, protection class, etc., in the S7-1500, ET 200MP (<http://support.automation.siemens.com/WW/view/en/59191792>) system manual.

## Dimensional drawing

This section includes a dimensional drawing of the module on a mounting rail and a dimensional drawing with the front panel open. Always observe the specified dimensions for installation in cabinets, control rooms, etc.

### Dimensional drawings for CPU 1511-1 PN

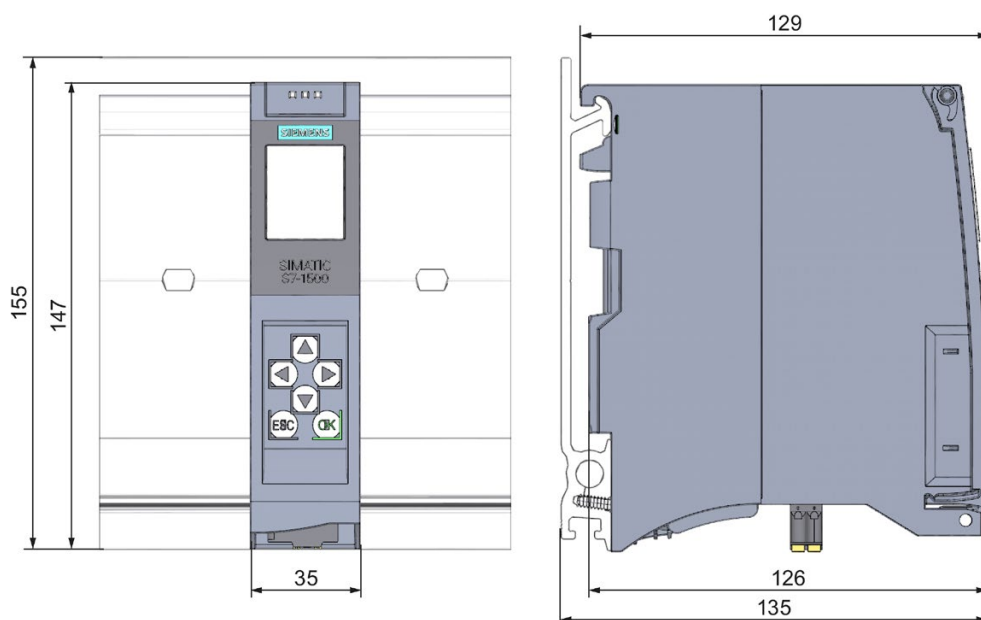

Figure A-1 Dimensional drawing of CPU 1511-1 PN, front and side views



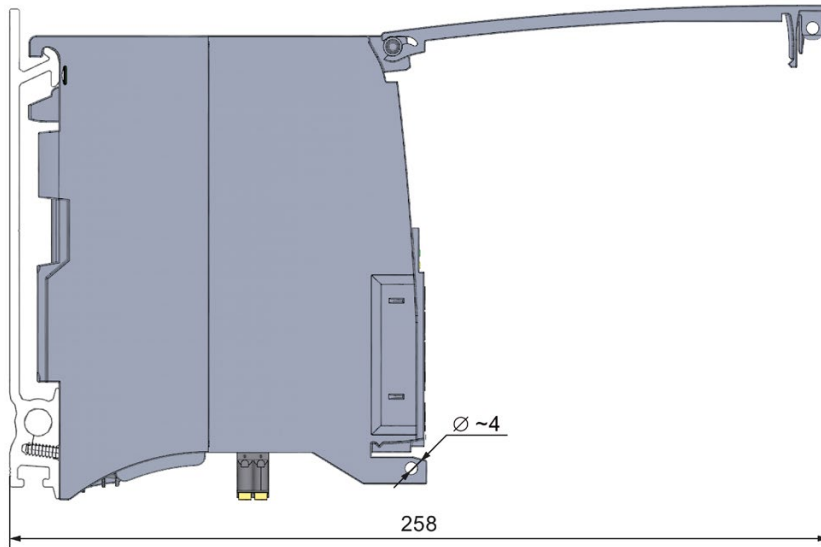

Figure A-2 Dimensional drawing of CPU 1511-1 PN, side view with front panel open